

formers and

6mm

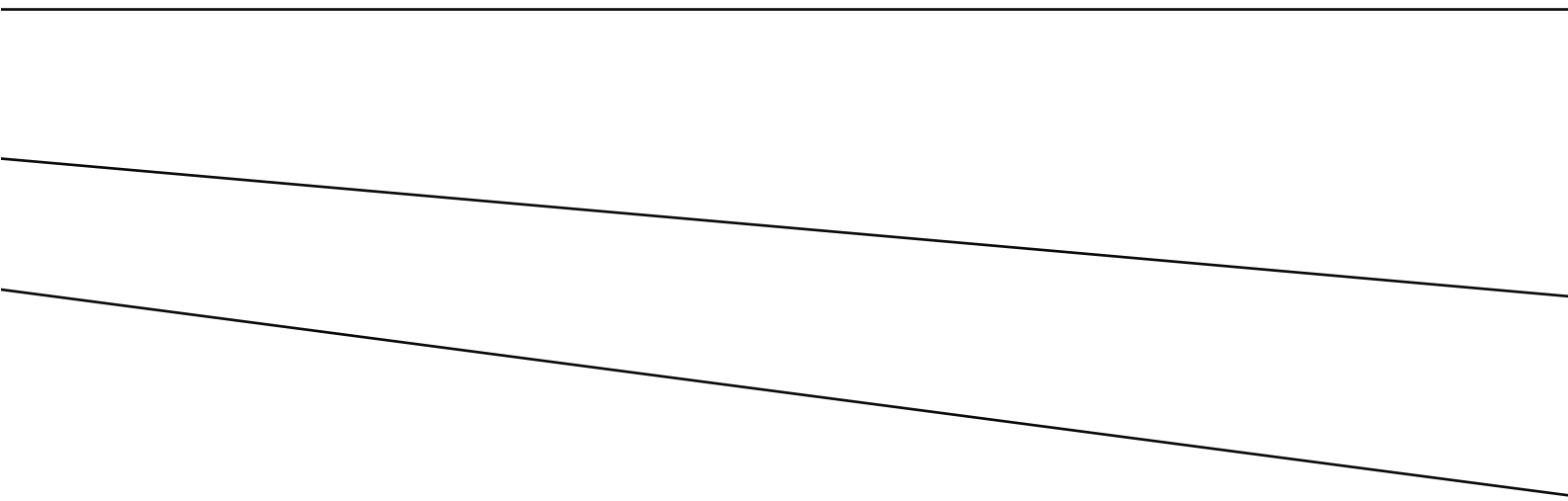

vertical / horizontal profile plates
in formers, make two

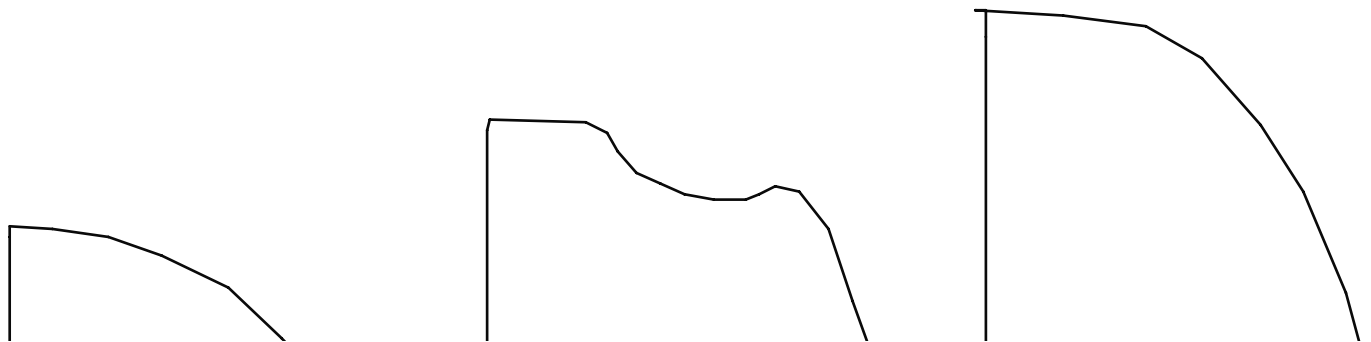

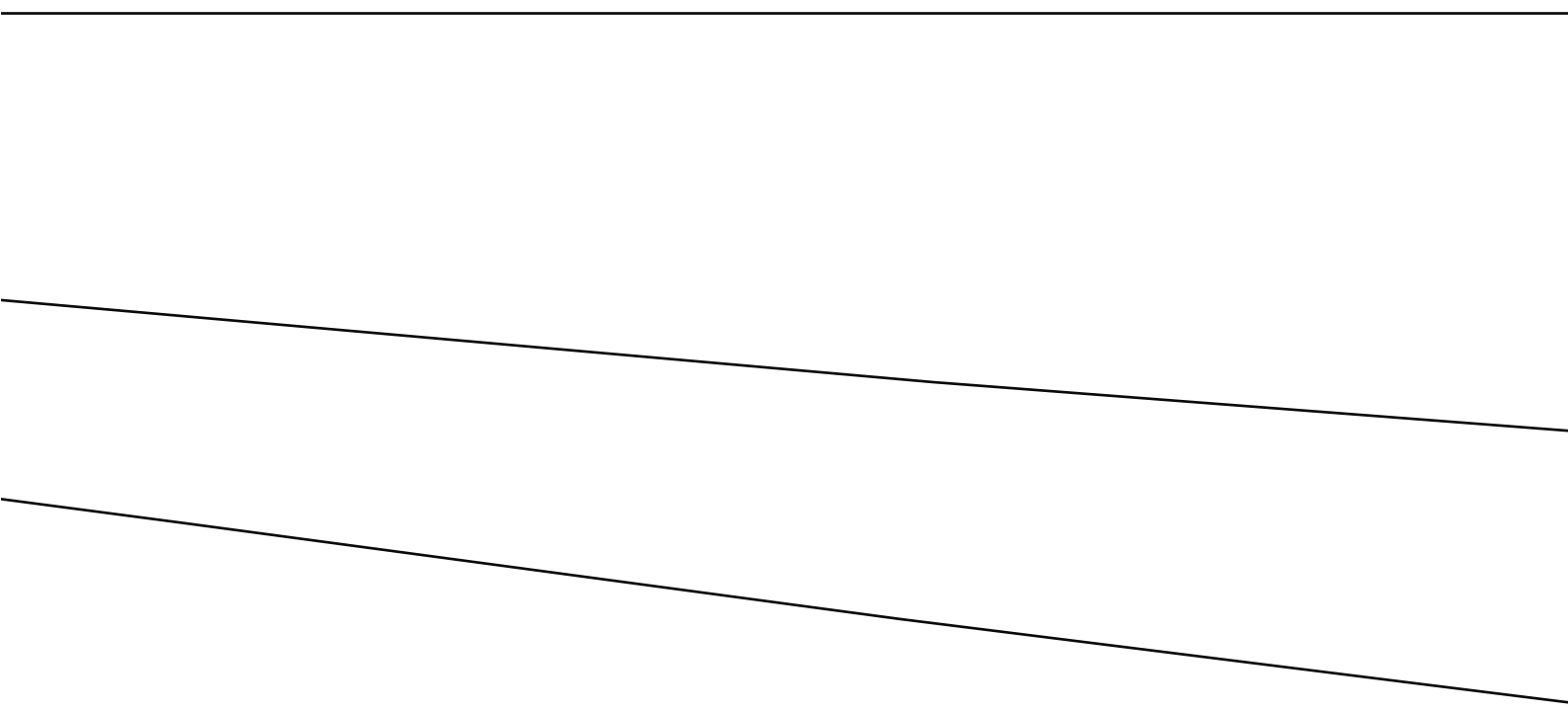

are resized for 3mm depron skin

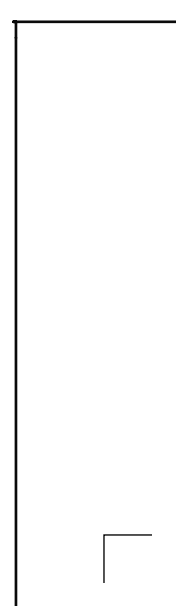
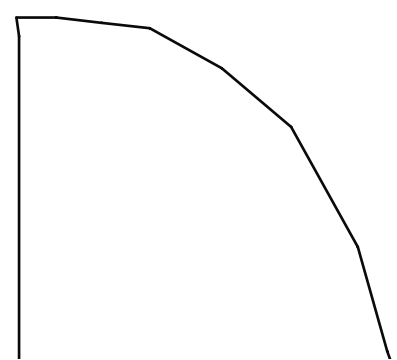

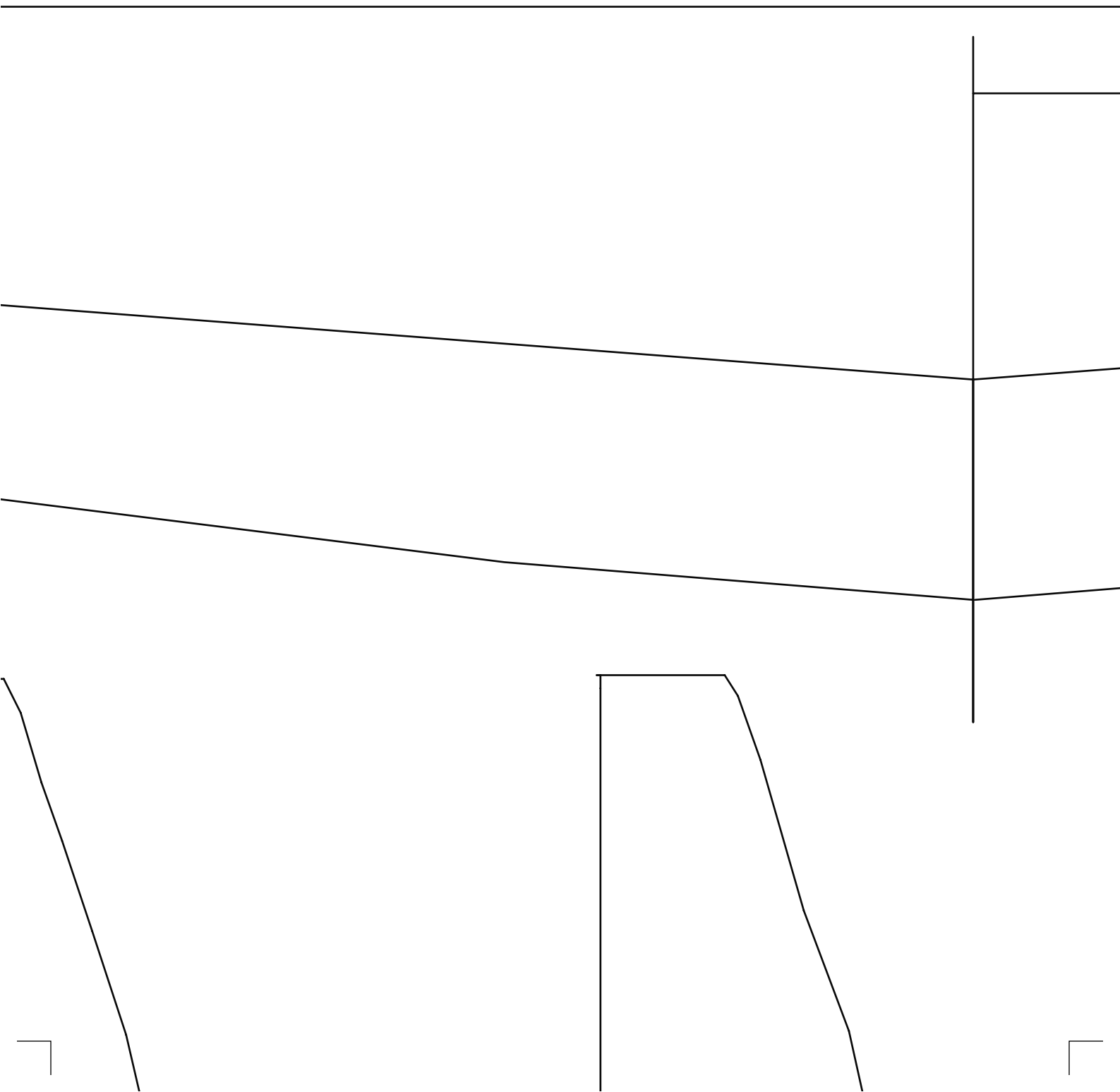

6mm depron

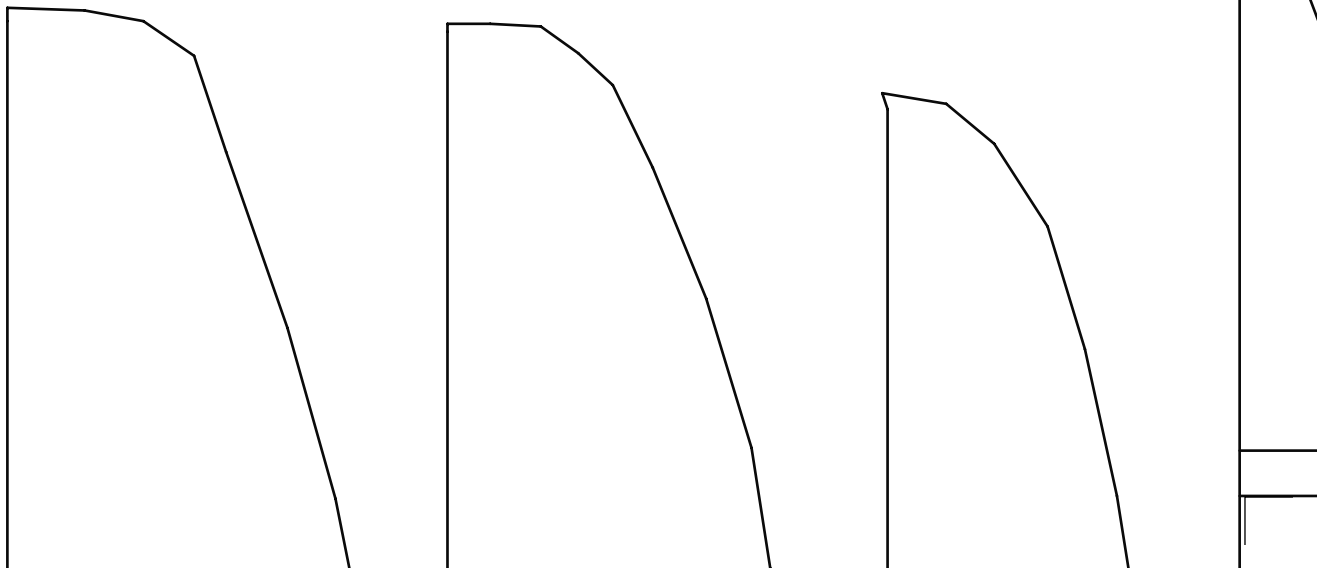

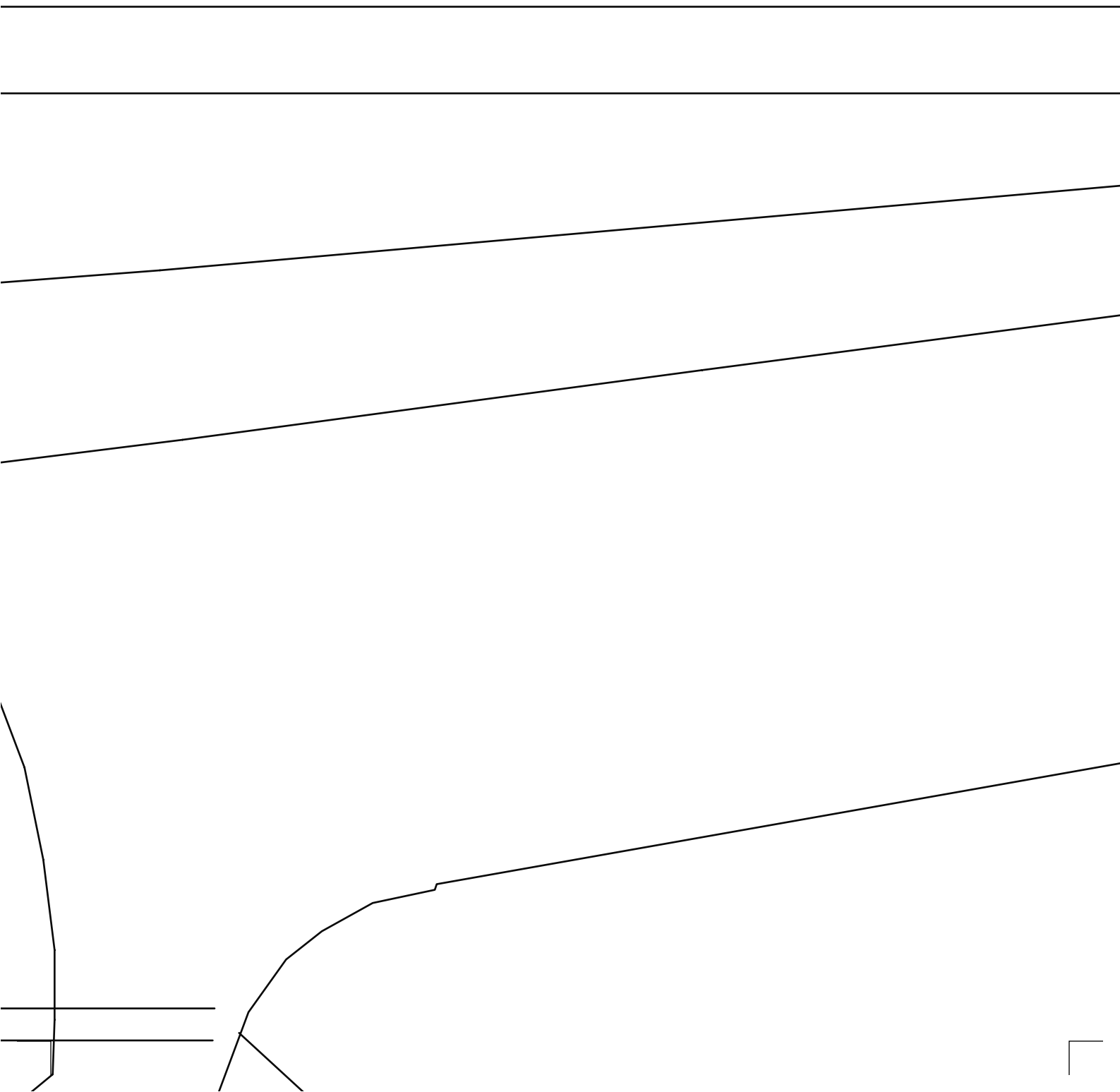

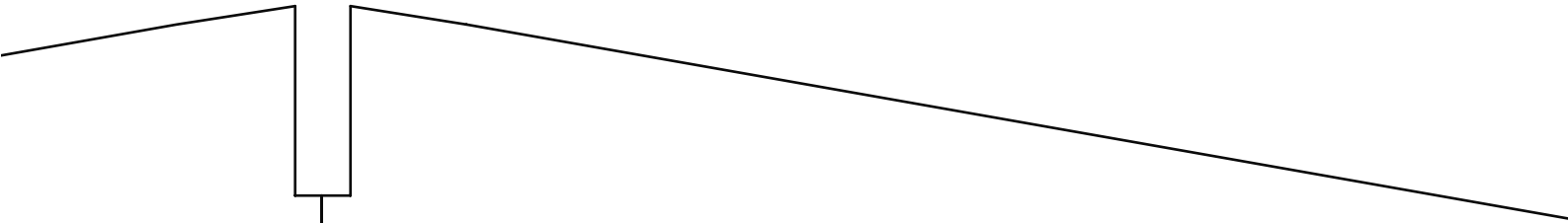
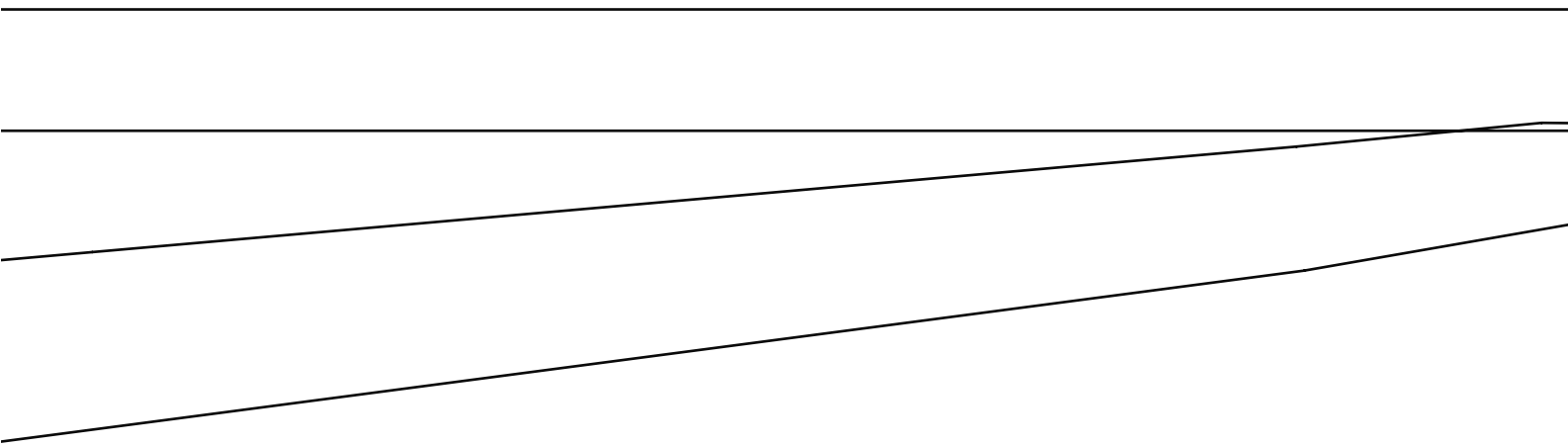

6mm depron

10 cm

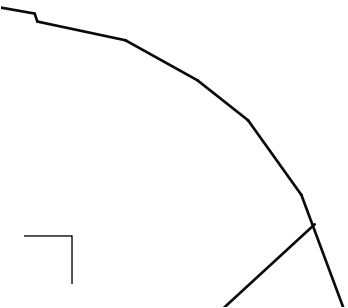
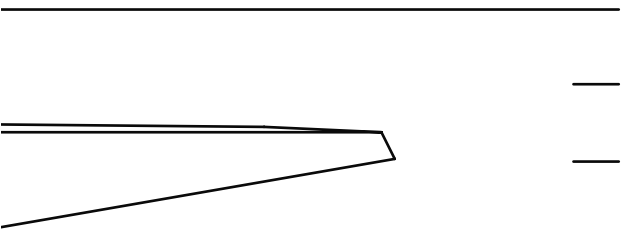

cut for



horizontal profil

cut for fixe

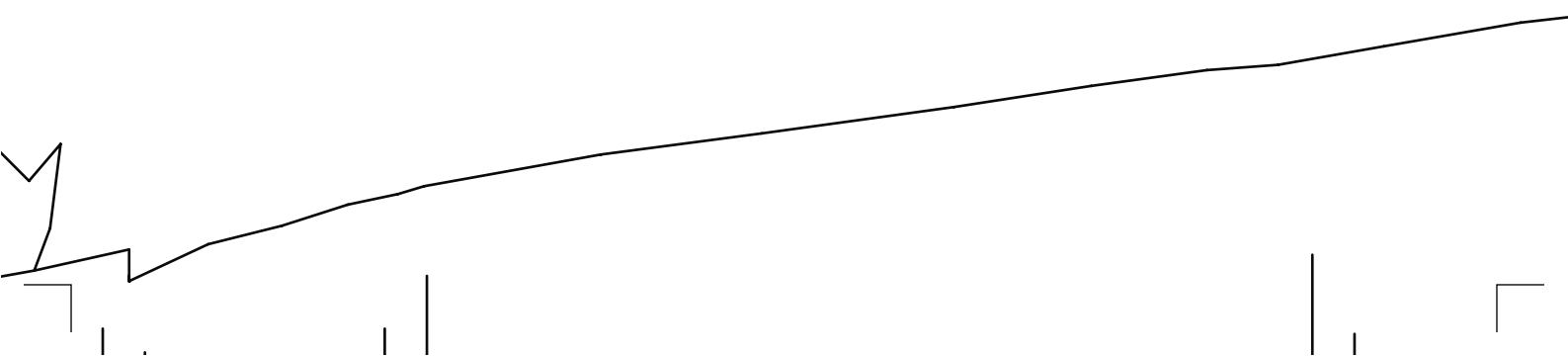

d wing

cut for fixed wing

c

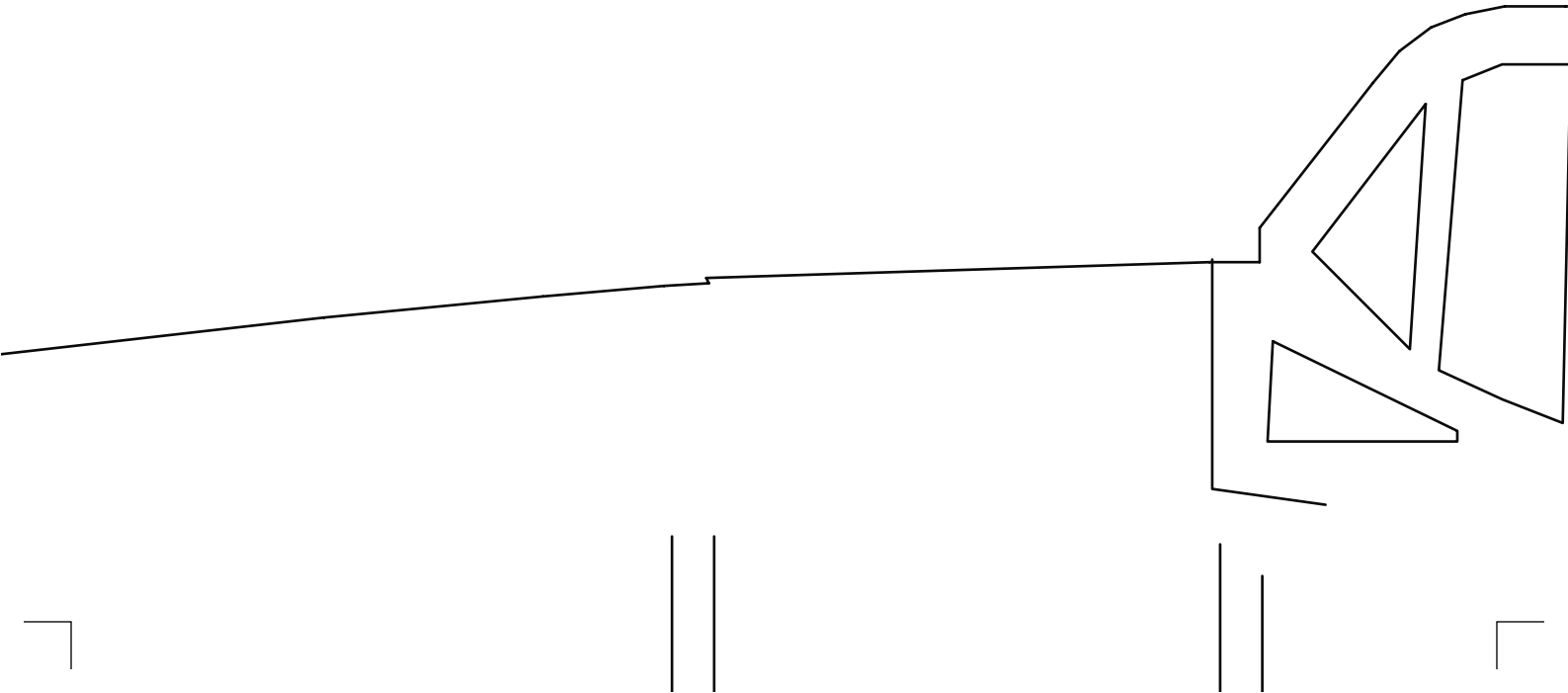

cut for fixed wing

cut for fixed w

6m

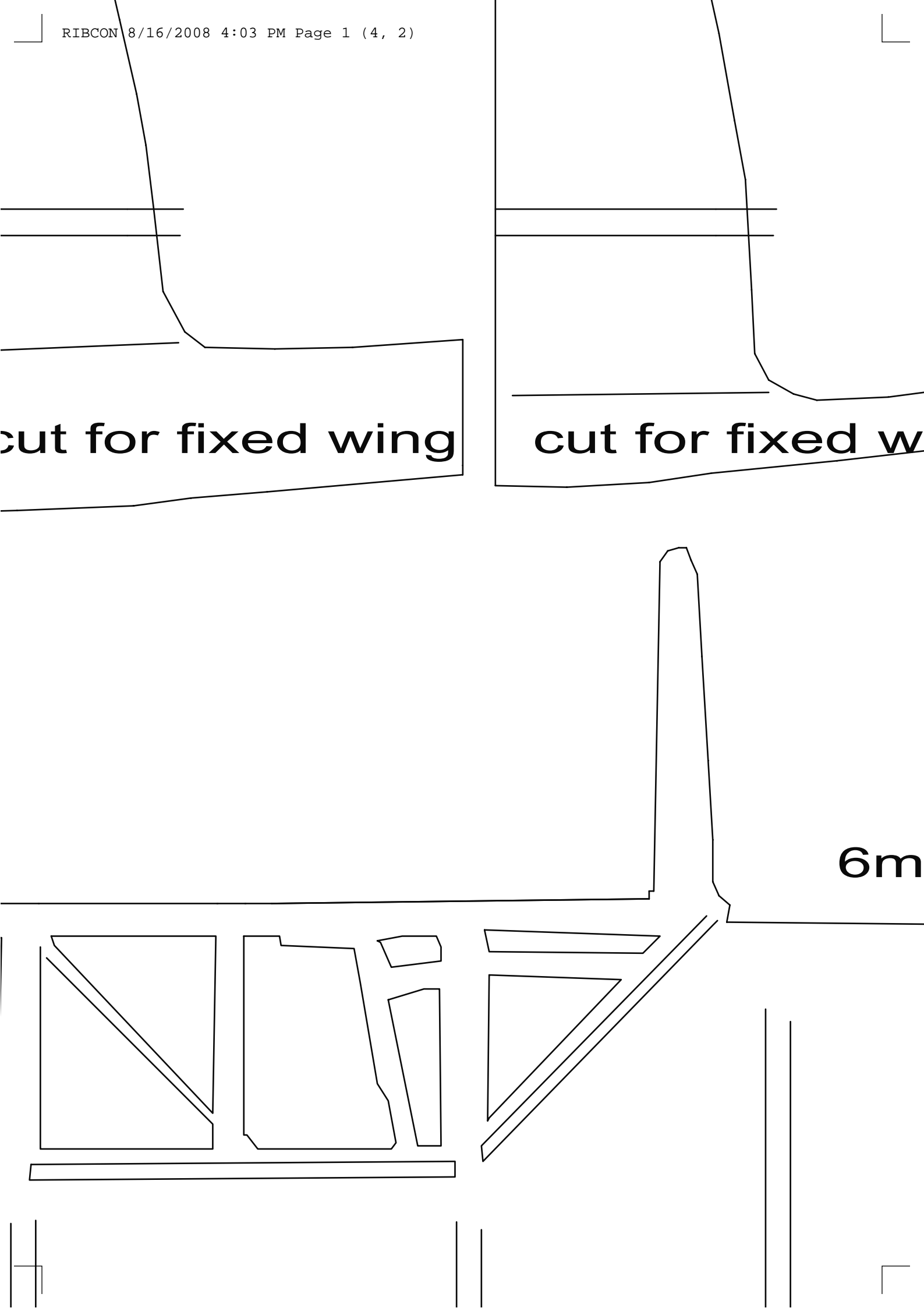

ing

m depron

elev



erator centre line

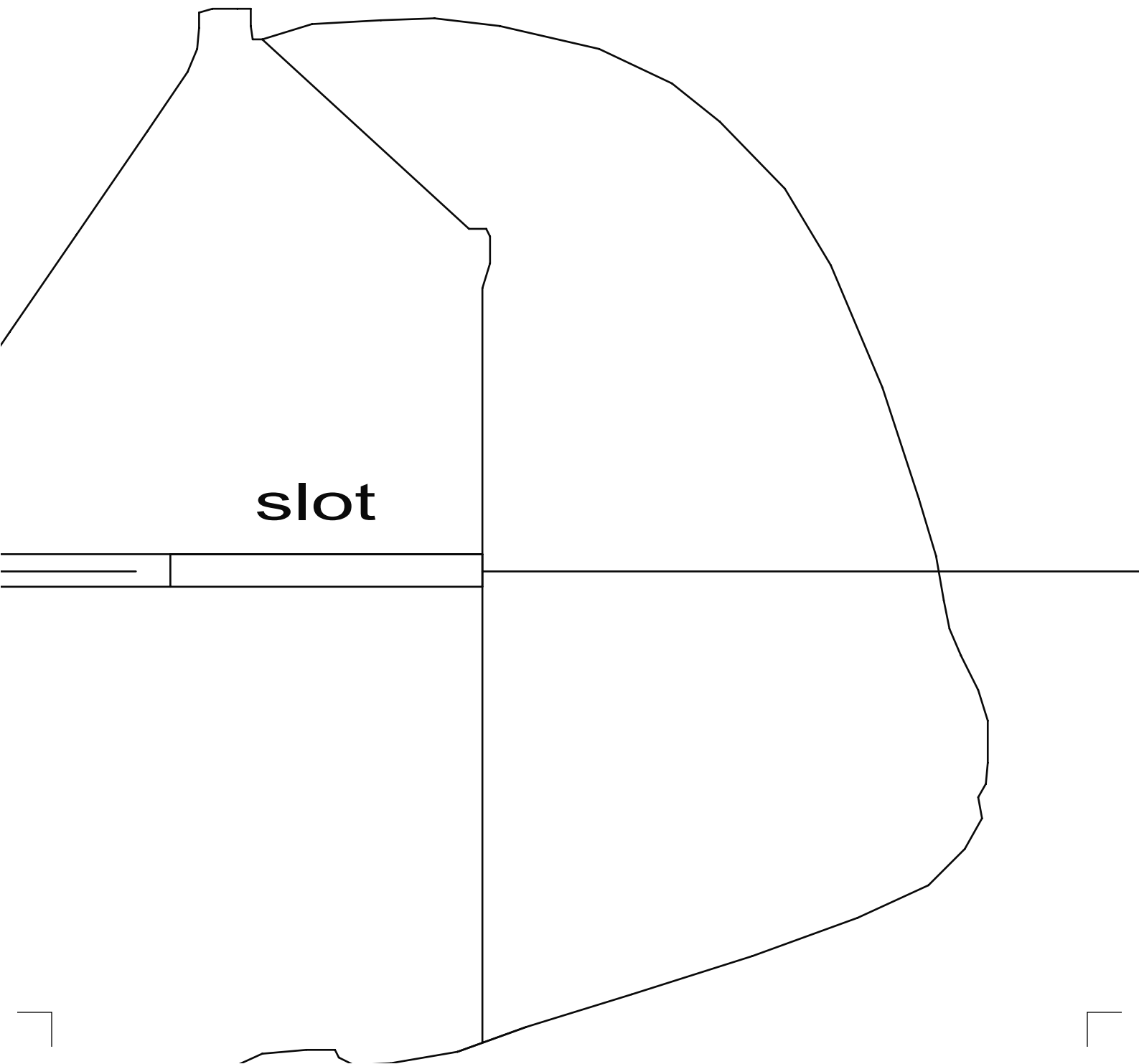
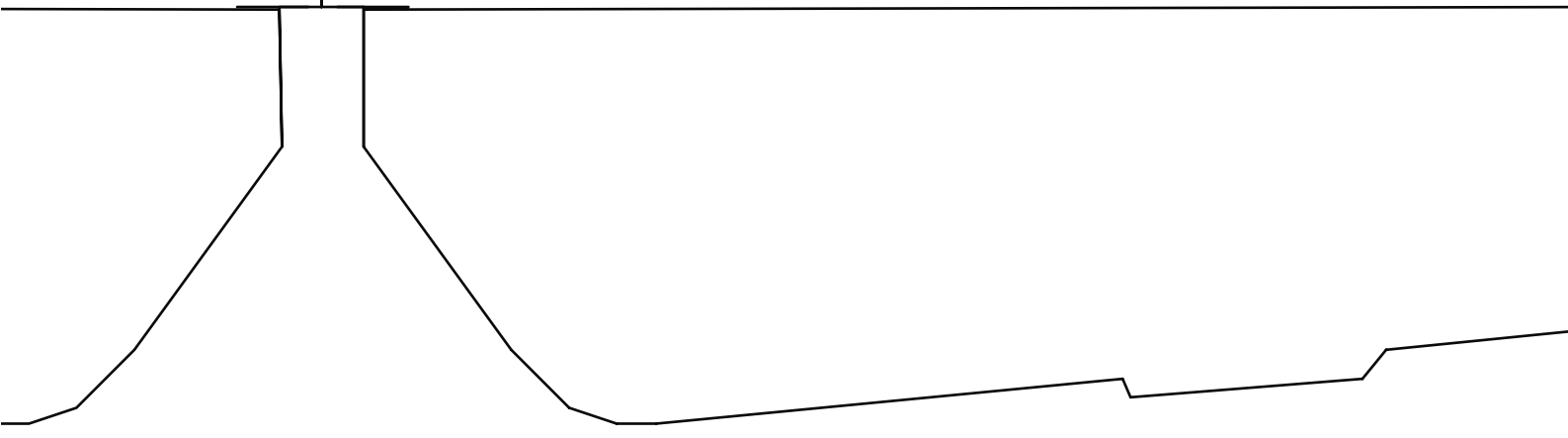

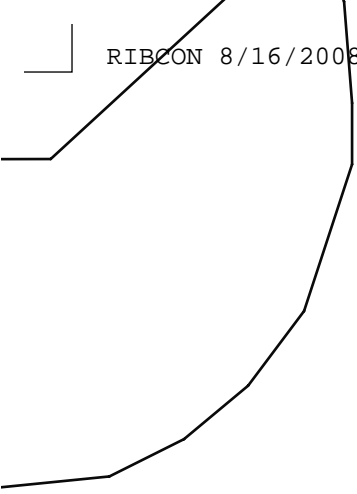

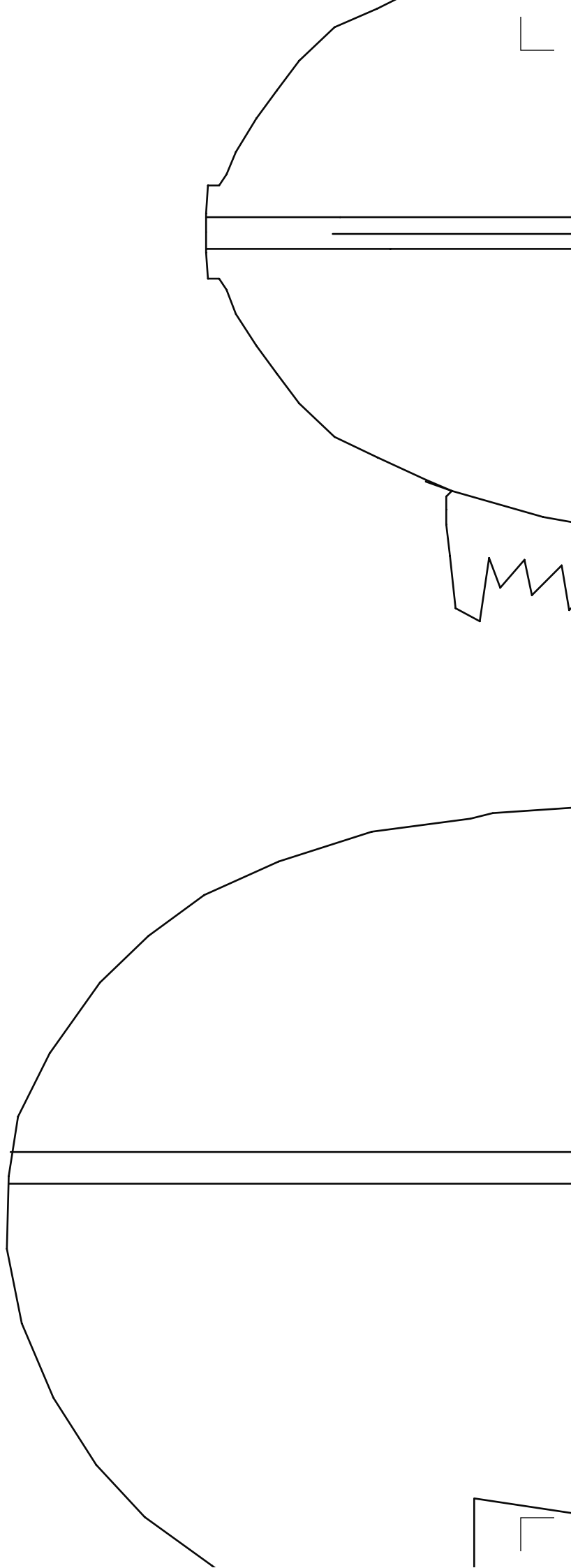

Dipl.-Ing. H

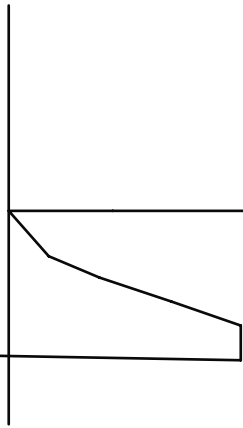

wing cent

ans-Joachim Wa

tre line

alter, Ottenweg 6

2 x 3mm depron

, 29308 Winsen



horizontal profil (left and right)



(Aller), Germany

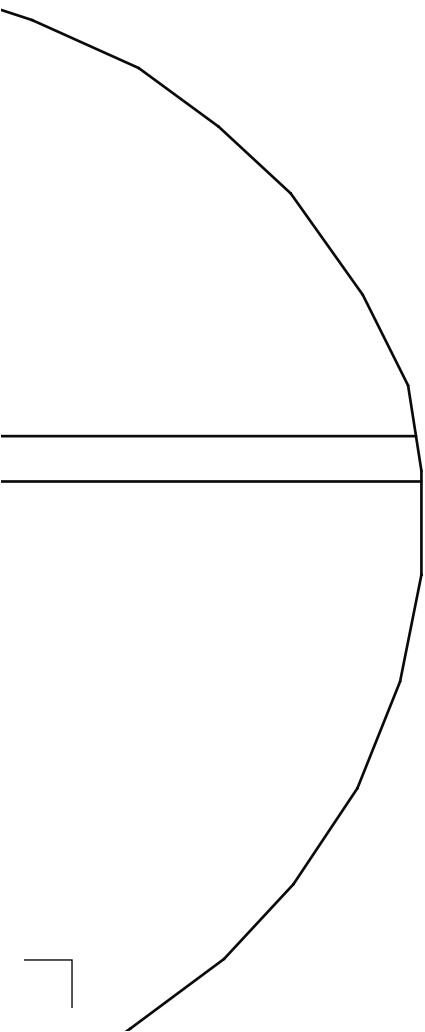

BF-
Only

109F, scale 1/7
y for privat use.

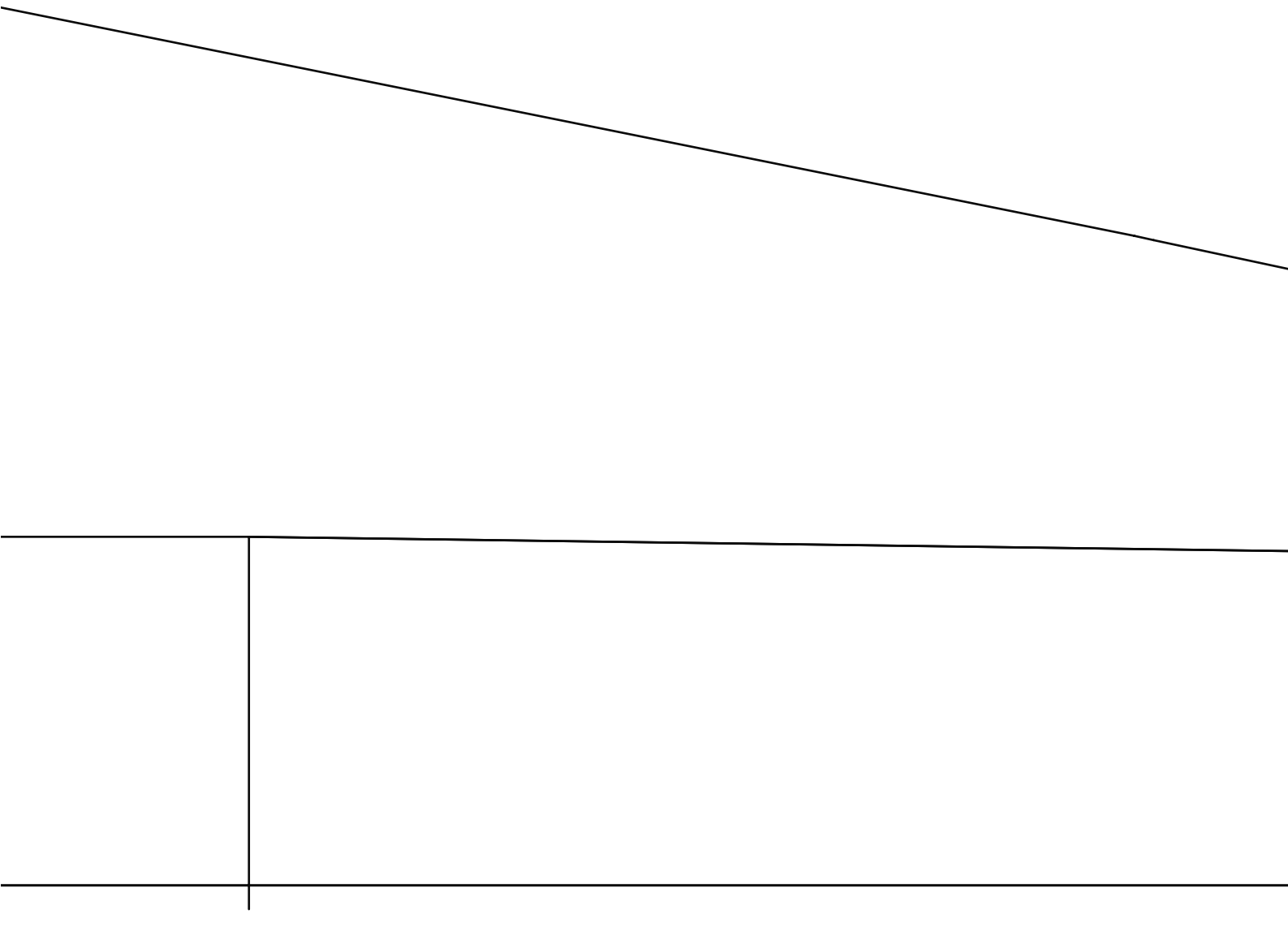

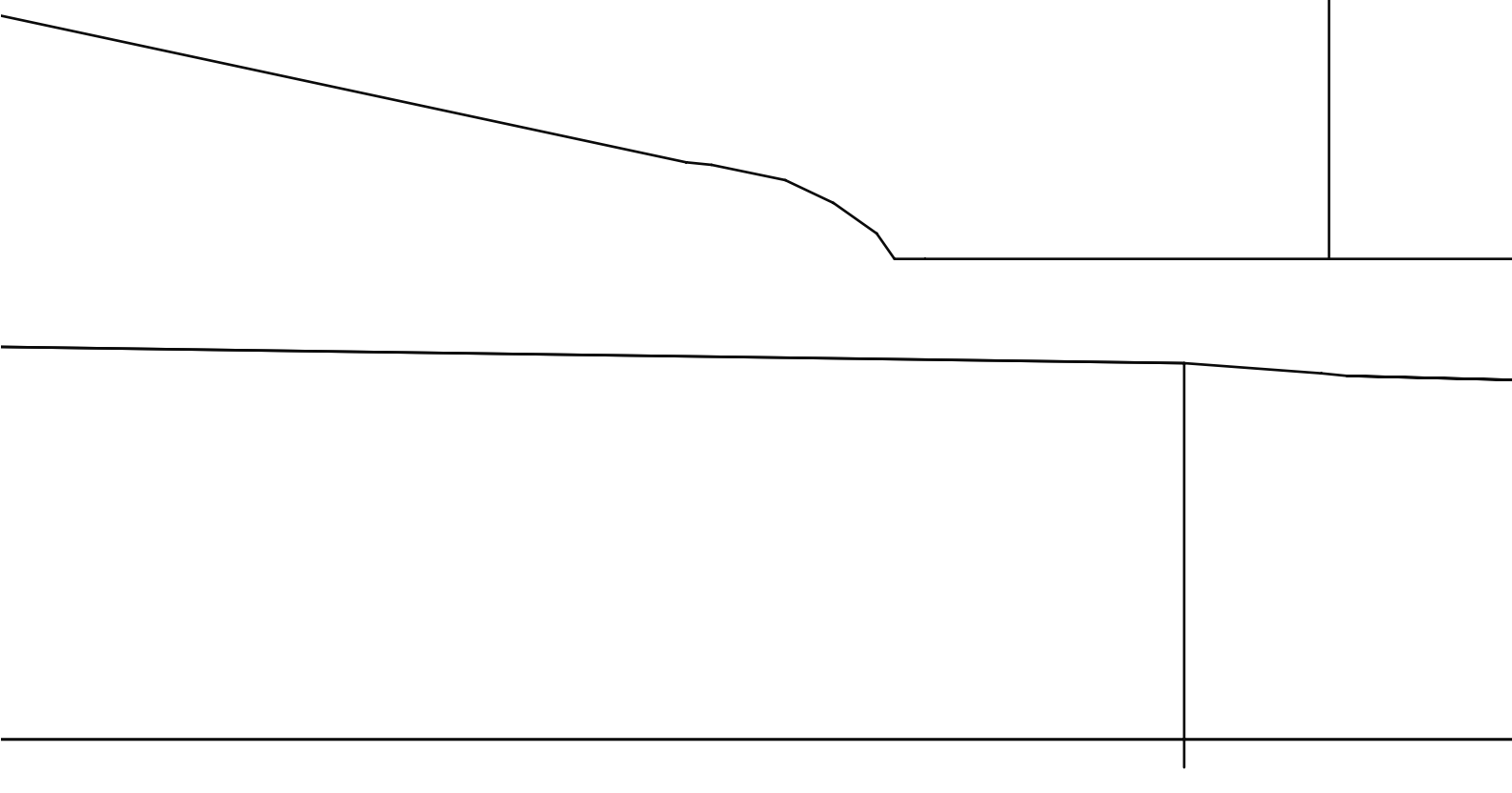

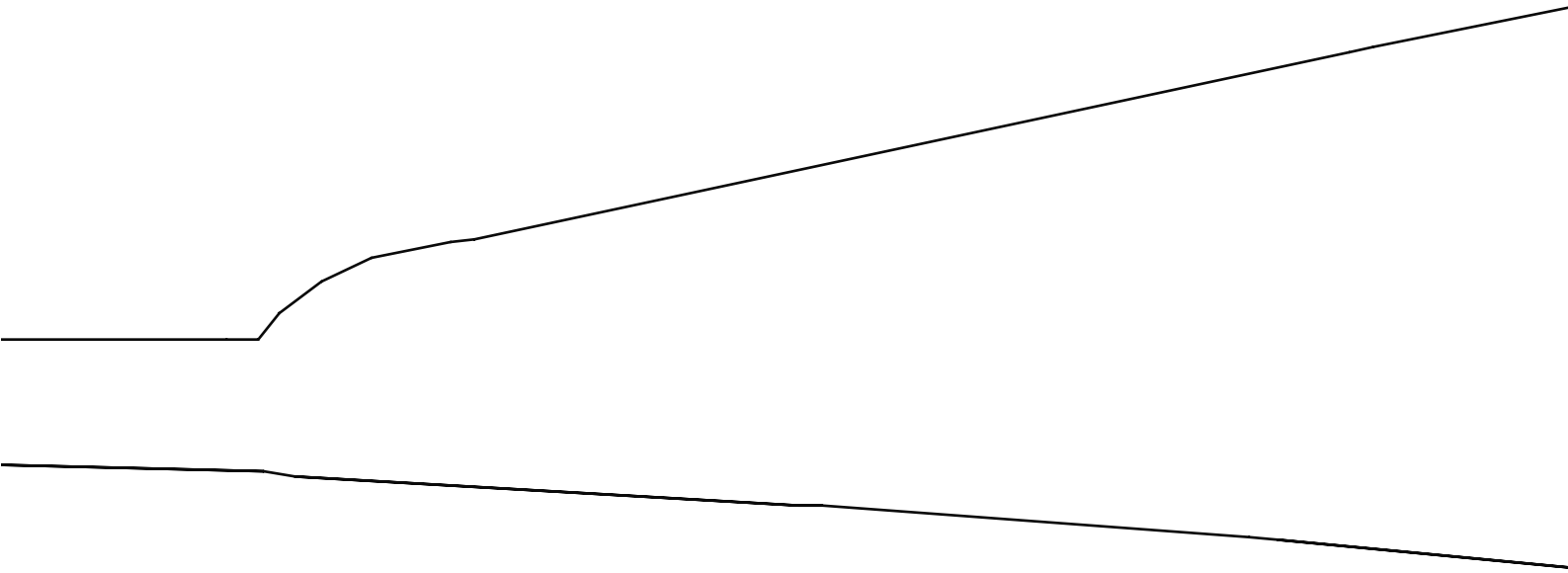

6mm depron 2 x horizontal pro

ofil

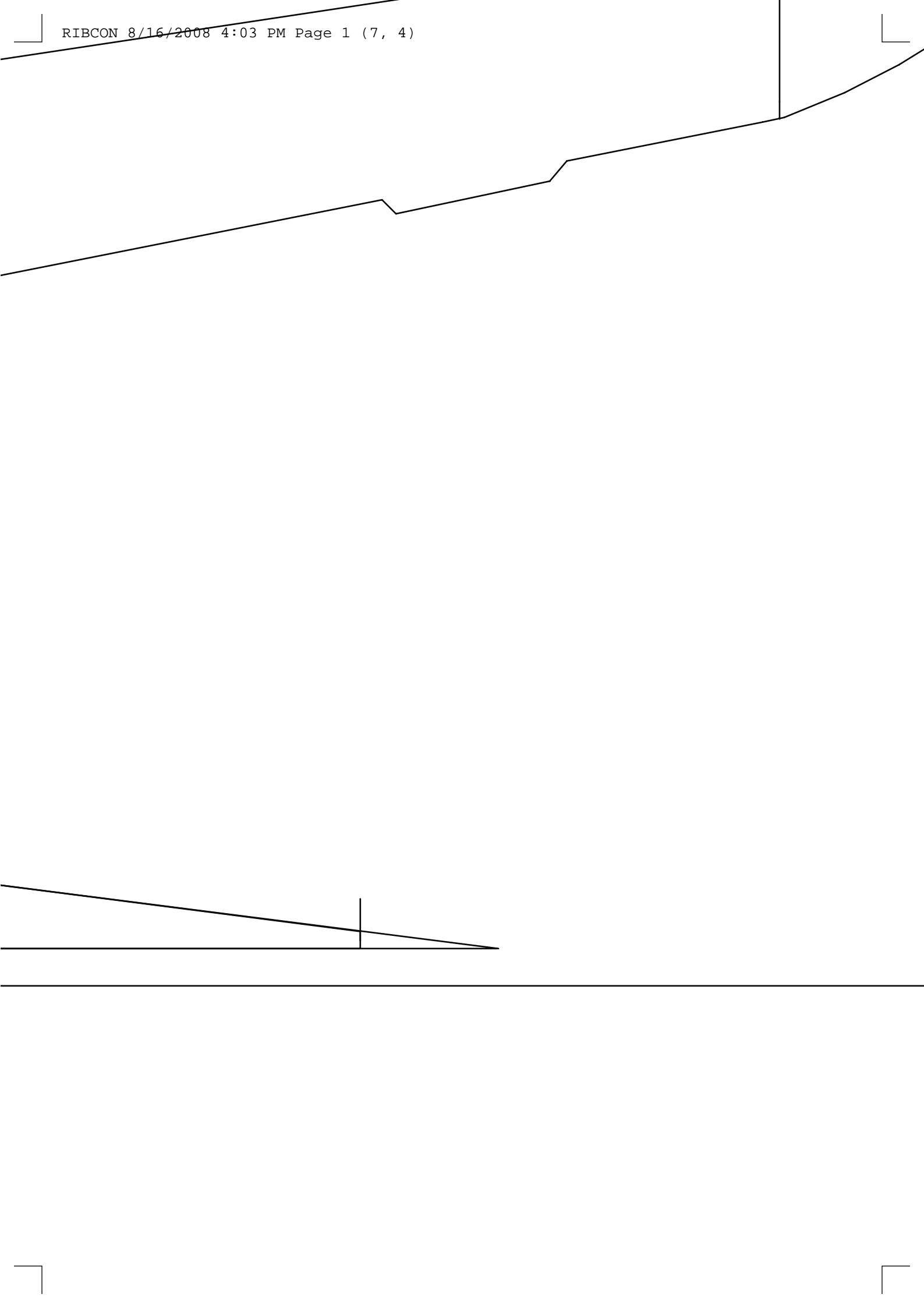

10 inc
